

COMUNE di PONZANO DI FERMO
PROVINCIA DI FERMO



Progetto di ristrutturazione, riqualificazione e adeguamento alla normativa vigente in materia di sicurezza e prevenzione incendi della scuola dell'infanzia e primaria "Gianni Rodari"

PROGETTO ESECUTIVO



LOCALITA' via F. Maggi

PROGETTISTA
Scandoni studio associati
ing. Maurizio Scandoni
arch. Riccardo Scandoni

TAVOLA	OGGETTO	SCALA
4b	ELABORATI GRAFICI	1:100
	_ piante _ prospetti _ sezioni stato modificato	DATA 14/03/14

_PIANTA PIANO SOTTOSTRADA scala 1:100

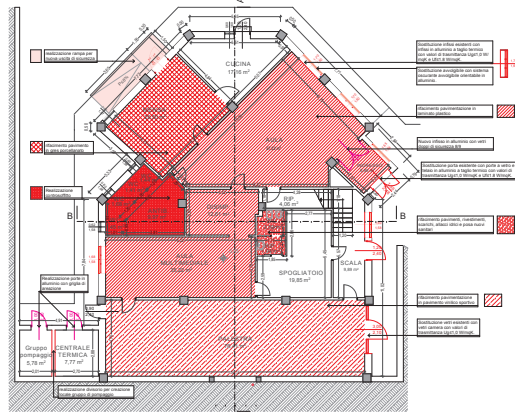

_PIANTA PIANO TERRA scala 1:100

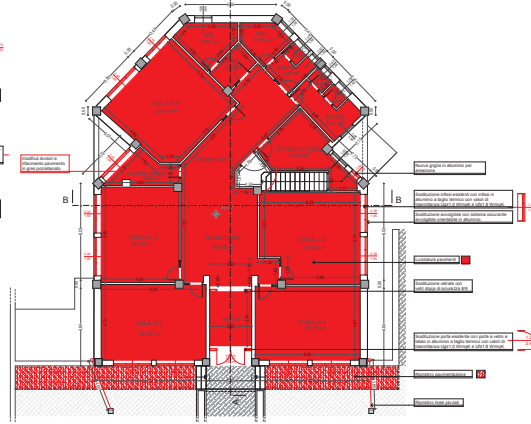

_PIANTA SOTTOTETTO scala 1:100

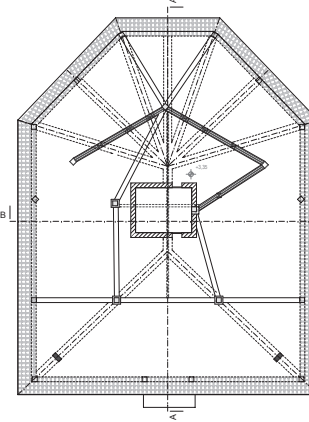

_PIANTA COPERTURA scala 1:100

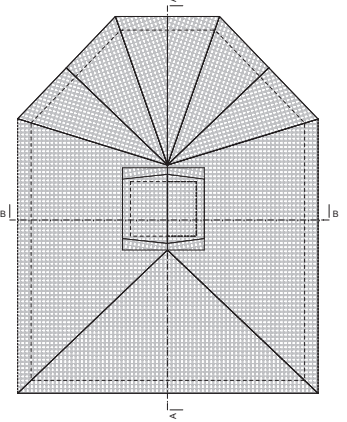

PROSPETTO SUD



PROSPETTO EST



SEZIONE A-A scala 1:100

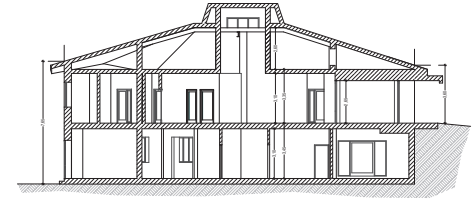

PROSPETTO NORD



PROSPETTO OVEST



SEZIONE B-B scala 1:100

